



*rsup*TM



THE UNION OF
PAGING AND CELLULAR
TECHNOLOGIES

User's Guide

INTRODUCTION

Your RSVP Numeric Display Pager turns any Motorola Micro-TAC™ or retail pocket personal cellular telephone into the ultimate personal communicator. RSVP also features a removable and rechargeable, ultra-thin, Nickel-Metal-Hydride cellular battery.

RSVP slides onto the back of your phone in place of the existing battery unit, providing the control and convenience of a pager and a phone in a single unit.

RSVP allows you to manage your cellular phone traffic, return calls at your convenience, screen calls, extend phone battery life, and even remain accessible while your phone is turned off.

Paging Features Summary:

- Eight numeric message slots
- Displays time of day
- Message time stamping
- Programmable alarm
- Retains messages while turned off and when replacing battery
- 12-digit numeric display
- Backlit display
- Musical alert
- Vibrate or audible mode with reminder alert

Battery Features Summary:

- Fits any Motorola MicroTAC or retail pocket personal cellular telephone
- Powerful and environmentally friendly Nickel-Metal-Hydride battery
- Battery is detachable from pager unit
- Spare batteries are small enough to carry in a shirt pocket
- One hour talk time, eight hours standby

USING THIS GUIDE

This user's guide describes the following:

- How to remove your cellular phone's existing battery
- Set up and operate your pager
- Maintain your RSVP pager in top operating condition
- Use the RSVP cellular battery and optional charger adapter

**PROCEDURE FOR CONNECTING YOUR NEW
RSVP PAGER TO YOUR CELLULAR PHONE**

Remove battery from any Motorola MicroTAC or retail pocket personal cellular telephone in the following manner:

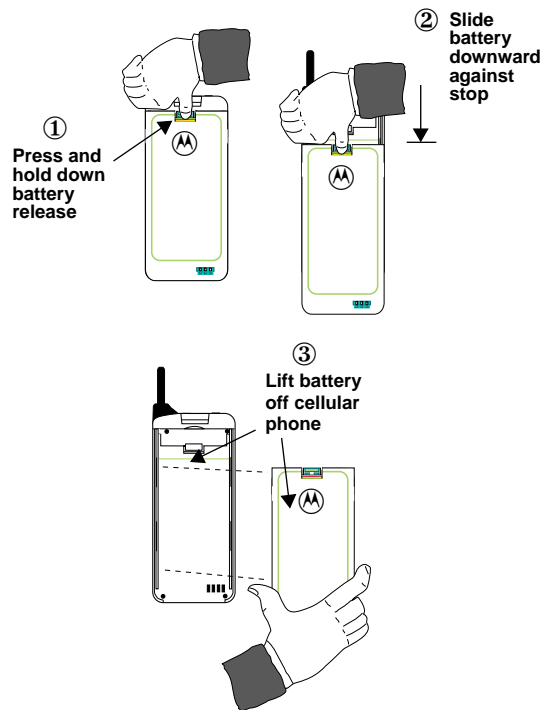

Note: Ensure the Nickel-Metal-Hydrate battery is fully charged and installed in the RSVP pager before performing this procedure.

Install your RSVP pager in place of the cellular phone battery in the following manner:

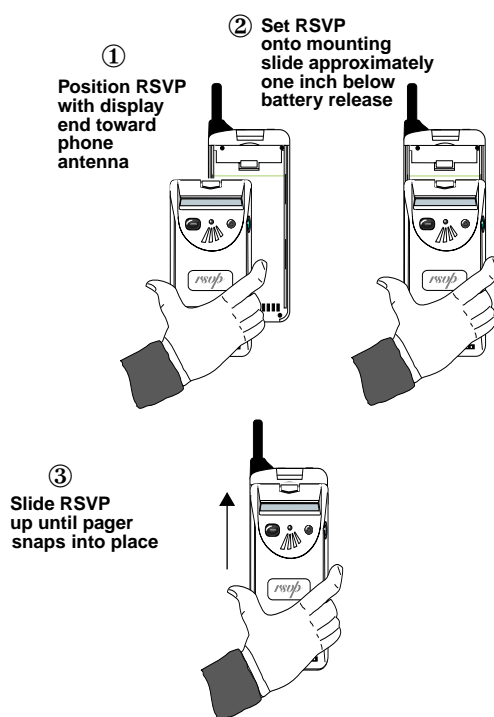

PAGING SERVICE ACTIVATION

Paging service providers require certain procedures for activating your RSVP pager. Contact your service provider to activate paging service.

CONTROLS AND DISPLAY INDICATORS

The locations and descriptions of the RSVP pager controls and display indicators are shown below:

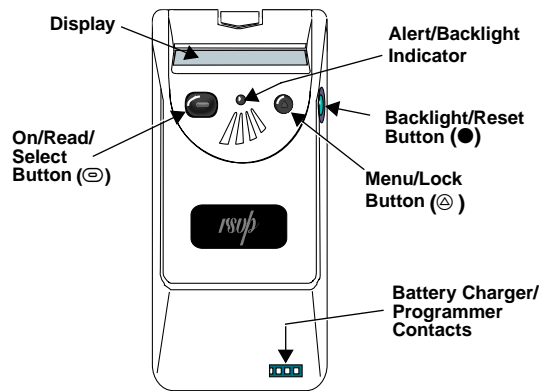

Pager Display:

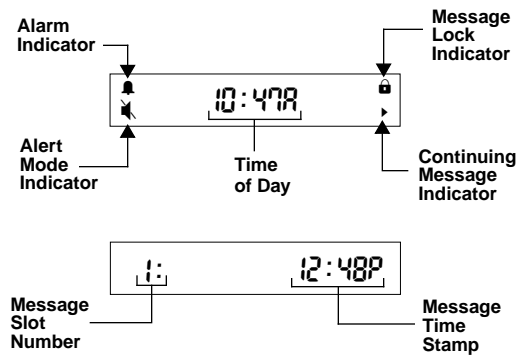

TURNING YOUR PAGER ON

Press **⊖** to turn your pager on. Your pager will alert indicating that it is on.

The time of day and the "Alert Mode" indicator, silent (🔇) or audible (🔊), is displayed.

READING MESSAGES

The RSVP pager can receive up to eight 20-character messages. When a message is received, the pager alerts with an audible or a vibrate alert, and a flashing alert indication. Press any button to stop the alert. Display your message as follows:

1. Press the **⊖** button to display your message.

Messages that contain more than 12 characters are continued on a second screen. The **▶** indicator means a second screen exists.

2. Press **⊖** to advance to the second screen. If not selected, the second screen is automatically displayed after one minute.

The last screen of your message displays the message slot number and the time the message was received.

If a message is left unread, the pager emits a reminder alert every two minutes, and the number of unread messages is displayed.

3. The pager automatically returns to the main status display after approximately eight seconds.



TURNING ON THE BACKLIGHT

In low light conditions, press **●** on the display backlight. Press **●** again to turn off backlight or allow it to turn off automatically.

RESET



Pressing the **●** button twice always resets the pager back to the main display menu.

CHANGING ALERT MODES

1. Press . Either "Silent?" or "Audio?" is displayed, depending on the current mode.
2. To change the alert mode, press .

For your pager to vibrate, it must be in the "silent" mode.







TURNING YOUR PAGER OFF

1. Press  until the "PAGER OFF?" prompt is displayed.
2. Press  to turn the pager off.

With the pager off, the clock is shown on the display, but not the "Alert Mode" indicator.

SETTING THE ALARM

Your pager's alarm can be set to alert you to a certain time of day. Set the alarm as follows:





1. Press  until "SET ALARM?" appears on your display.
2. Press  to select alarm on/off sequence.
3. To move to the next digit, press . To advance through each digit, press . Repeat this process for each field (On/Off, hours, minutes, AM/PM).
4. Press  to turn the alarm on or off.
5. Press the  button twice to return to the main display menu.

The  indicator appears on the display when the alarm is turned on. At the selected time, the alarm vibrates or emits a unique 20-second alert and "ALARM" is displayed.

1. Press any button to stop the alarm alert.



SETTING THE TIME

Set the displayed time as follows:



1. Press  until "SET TIME?" is displayed. Then press  once.
2. Press  until desired hour appears.
3. Press  to move to the next digit.
4. Repeat process for each field (hours, minutes, AM/PM).
5. Press the  button twice to return to the main display menu.

LOCKING AND UNLOCKING MESSAGES

Locked messages cannot be erased or overwritten by new messages when memory is full. Also, they are not lost while replacing the battery. Up to four messages may be locked at one time. Lock your messages as follows:

1. Press  while reading your message. A lock () appears on the display to indicate your message is protected.
2. To unlock your message, press  while reading the locked message.

ERASING MESSAGES FROM MEMORY

1. Press  until "ERASE ALL?" appears on the display.
2. Press . This erases all of your read-unlocked messages.

The "ERASE ALL?" prompt is displayed if there are read-unlocked messages in memory.

BATTERY FEATURES

The RSVP pager features a removable and rechargeable Nickel-Metal-Hydride cellular battery unit. RSVP replaces your cellular phone's battery and provides charging contacts in an identical location. Your existing cellular charger may be used to charge your cellular/pager unit, or with the optional adaptor, you may also charge a spare battery in your cellular charger.

BATTERY REPLACEMENT

Remove RSVP from your cellular telephone and replace the RSVP battery as shown below:

Press release ①
then slide pager
downward away
from antenna

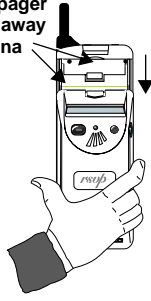

② Lift pager
away from
cellular



③ Turn pager over,
insert tip of ball
pen under release
and pry up on
release, then lift
battery out of
pager

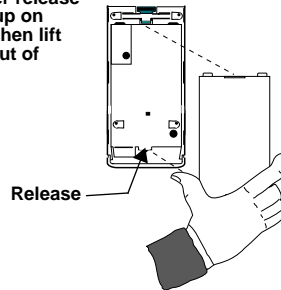

Install your new battery in the reverse order of removal.

CHARGING YOUR BATTERY

Your battery may be charged while attached to your cellular phone or separately using the optional adapter shown in the following illustration:

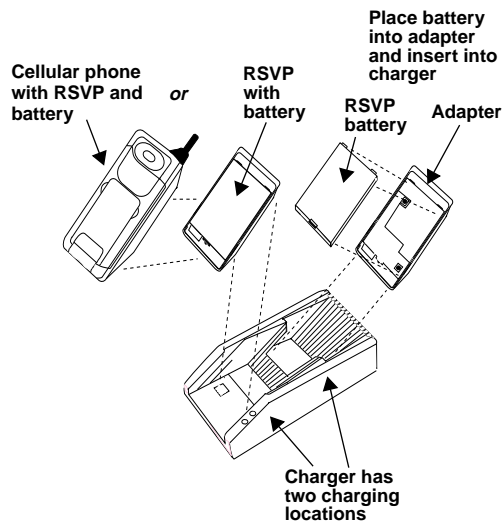

Refer to the charger manufacturer's instructions for specific use of your charger.

PROPER CARE

The RSVP pager is durable, reliable, and can provide many years of dependable service, but it is a precision electronic product. Water and moisture, excessive heat, and extreme shock may cause damage to the pager. Avoid exposing your pager to these conditions.

CLEANING YOUR RSVP PAGER

To clean smudges and grime from the exterior of your RSVP pager as well as your cellular phone, use a soft, non-abrasive cloth moistened in a mild soap and water solution. Rinse the surface using a second cloth moistened in clean water. Do not use alcohol or other cleaning solutions.

REPAIR AND MAINTENANCE

Your RSVP pager properly handled is capable of many years of trouble-free service. However, should it ever require service, Motorola's Service Organization, staffed with specially trained technicians, offers conveniently located repair and maintenance facilities throughout the world.

PATENT INFORMATION

This Motorola product is manufactured under one or more Motorola U. S. patents. A listing of these patents is provided on the inside surface of the battery compartment. Other U. S. patents covering this product are pending.

© Copyright 1995, Motorola, Inc. All Rights Reserved. Motorola Derivative Technologies Division,
3301 Quantum Blvd., Boynton Beach, FL 33426, Printed in U.S.A. 10/95, ®, Motorola, MicroTAC,
and RSVP are trademarks or registered trademarks of Motorola, Inc.
Contents of this manual subject to change without notice

